

EVs SEC

Size Exclusion Chromatography Columns for EVs isolation from biological fluids

1. INTRODUCTION

Extracellular vesicles (EVs) are thought to provide a means of intercellular communication (2,3) and of transmission of macromolecules between cells allowing the spread of proteins, lipids, mRNA, miRNA and DNA and as contributing factors in the development of several diseases. EVs can also modulate cancer microenvironment (4) and the immune response (5,6) and are recognized as potential markers of human diseases, including cancer. In particular, due to their presence and stability in most body fluids and the similarity of their content with tumor cells, EVs have great potential as non-invasive biomarkers for liquid biopsy. Nevertheless, the use of EVs for diagnostic purposes has been limited by the lack of reproducible isolation methods (7). About isolation methods, ultracentrifugation remains by far like the most widely used primary method despite it is a time consuming method, that provide aggregated proteins and nucleic acid may be pelleted and is not very suitable for small sample volumes. In this sense, size exclusion chromatography (SEC) has been described as most efficient method for isolating EVs from complex biological fluids by single-step (8), with a good recovery and with almost complete removal of contaminants, such as proteins and lipoproteins.

2. PRODUCT DESCRIPTION

Immunostep has developed SEC columns for EVs isolation from complex biological fluids such as: plasma, serum, urine and cerebrospinal fluid.

SPECIFICATIONS

Reference	SEC7012	SEC3512
Separation size	70-1000 nm	35-350 nm
Volumetric Flow Rate at RT	>0,75 ml/min	>0,75 ml/min
Sample volume	500 µl	
Column volume	10 ml	
Void volume	3 ml	
pH stability working range	3-13	
pH stability cleaning in place (CIP)	2-14	
Shelf life	12 months at 2-8°C	

*Columns available for lower volumes (optimal of 150 µL). Ask us for more information about them.

The kit includes a stopcock for each column.

3. REAGENTS PROVIDED

DESCRIPTION	REFERENCE	COLUMNS (UNITS)
12 ml SEC columns, which a diameter of 1.56 cm and 7.9 cm high, packed with a resin for a separation size of 35-350 nm .	SEC3512-4	4
	SEC3512-8	8
12 ml SEC columns, which a diameter of 1.56 cm and 7.9 cm high, packed with a resin for a separation size of 70-1000 nm .	SEC7012-4	4
	SEC7012-8	8

*Columns available for lower volumes (optimal of 150 µL). Ask us for more information about them.

4. APPROPRIATE STORAGE AND HANDLING CONDITIONS

Store the columns at 2-8 °C in the presence of a bacteriostatic agent (e.g. filtered PBS containing Sodium Azide 0.09% or 20% ethanol). This one can be introduced during the rinsing step. Keep columns upright.

5. APPROPRIATE STORAGE AND HANDLING CONDITIONS

Running buffer is not supplied. Some examples of buffers that can be used are:

- PBS 20 mM, 0.32% trisodium citrate (pH 7.4, 0.22 mm filtered and degassed).
- PBS 20 mM, 150 mM NaCl (pH 7.2, 0.22 mm filtered and degassed)

It is recommended to use buffers with an ionic strength of 0.15 M or higher, because in low ionic strength buffers, the concentration of competing buffer ions is low, and contaminant proteins spend most of their time adsorbed to binding sites on the stationary phase. For buffer choice it is also important consider the downstream protocol for isolated vesicles. For example citrate buffers could interfere with molecular biology protocols.

Note: All buffers must contain sodium azide.

6. EVIDENCE OF DETERIORATION

Columns are reusable up to 5 times and should not be used if any evidence of deterioration is observed. For more information, please contact our technical service: tech@immunostep.com.

7. RECOMMENDATIONS AND WARNINGS

- The column anti-bacterial solution contains sodium azide. In acid conditions, it is transformed into hydrazoic acid, a highly toxic compound. Azide compounds must be diluted in running water before being discarded. These conditions are recommended so as to avoid deposits in plumbing, where explosive conditions could develop. The safety data sheet (SDS) is available online at www.immunostep.com
- The biological samples should be handled in the same way as those capable of transmitting infection. Appropriate handling procedures should be guaranteed.
- Do not use after the expiry date indicated on the column.
- Temper running buffer and columns before sample purification for an adequate Volumetric Flow Rate.
- For professional use only.

8. WARRANTY

Warranted only to conform to the quantity and contents stated on the label or in the product labelling at the time of delivery to the customer. Immunostep disclaims hereby other warranties. Immunostep's sole liability is limited to either the replacement of the products or refund of the purchase price.

9. PROTOCOL

- Place the column in a rack and level it, make sure the column is vertical. Column box can be used as a rack, as shown in figure 1.
- Remove the top cap carefully, as drastic changes in pressure could damage the column.
- Remove the bottom cap.

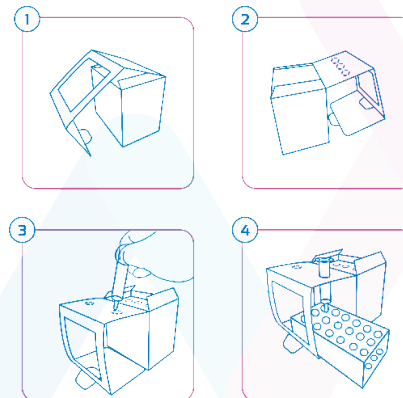

Figure 1. Graphic instructions to use column box as well as rack, avoiding to get a specific column rack in the laboratory and facilitating the protocol.

■ Column equilibration

- The column must be at room temperature (18°C – 24°C) for 30 minutes before use.
- Use only fresh filtered (0.2 µm) buffer to avoid particulate contamination.
- Rinse the column with 21 mL of running buffer (7,5 mL for the lower volumes columns).
- Do not allow the column to run dry. The top filter must stay wet.

■ Sample fraction collection

- Once the column is washed, add the sample onto the top filter (500 µL, and 150 µL for the lower volumes columns). Once it passes through the filter, fill the column with the running buffer.
- Let pass three drops of running buffer, and collect fractions of 500 µL (150 µL for the lower volumes columns) (minimum 12 fractions).
- When the column is used according to the protocol, the first four fractions (2,0 mL, and 600 µL for the lower volumes columns) is the void volume which does not contain vesicles. These vesicles elute predominantly in fractions 5, 6, 7 and 8 with removal of protein contamination. Fractions beyond 9 usually contain higher protein and lower vesicle levels (Fig 2).

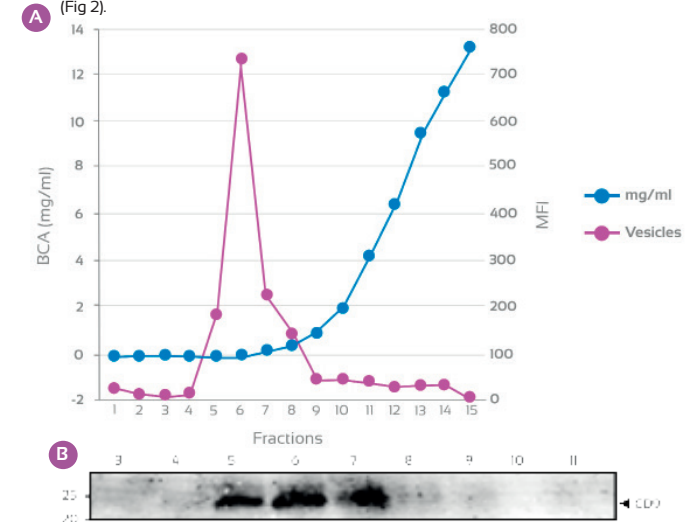

Figure 2. Amount of EVs and protein in each fraction from the column. A) Comparative of protein (BCA) vs vesicles (FACS CD63+/CD9+) content. B) Western Blot. SEC fractions were analyzed on SDS-PAGE and immunoblotted for CD9 tetraspanin with anti-CD9 (VJI/20), under non-reducing conditions

■ Column cleaning and storage

- After the collection of the vesicle fraction, rinse the column with 21 mL (7,5 mL for the lower volumes columns) of running buffer to rinse out all the protein and small molecules before the next sample application. NaOH cleanup is performed to remove precipitated proteins or other contaminants that may be accumulated on the column, a running buffer change, or a sample change. To do this, add 0.5mL (0,15 mL for the lower volumes columns) of sodium hydroxide (500 mM NaOH), then equilibrate the columns with 10 mL of water (3,5 mL for the lower volumes columns) followed by 21 mL of running buffer (7,5 mL for the lower volumes columns) immediately after cleanup. Note that the column should never be stored in sodium hydroxide.
- Put the bottom cap on.
- Put the top cap on carefully, as drastic changes in pressure could damage the column.
- Stopcocks cannot be heat sterilized as they do not withstand high temperatures. To sterilize them, it can be done by passing a 30% ethanol solution (5 mL) with the help of a syringe.

■ Fraction collection concentration

If the volume of the starting sample is small and / or the concentration and EVs is low in the sample, it is possible that the EVs will be much diluted in the collected fractions. In many cases, for downstream processing it is necessary to concentrate the fractions, for that, we recommended to use an Amicon Ultra-4, membrane PLHK Ultracel-PL, 100 kDa (Merck).

10. PERFORMANCE DATA

Below is a representative example of the isolation of EVs from a plasma by Immunostep SEC columns. Sample obtained can be subsequently analyzed by Abs (280) (Fig. 3A) and Abs (260/280) (Fig. 3B), which allows monitoring the elution of the sample, by conventional cytometry with the use of kits based on beads (Fig. 3C), such as Exostep (Ref. ExoS-25-P81), NTA (Fig. 4) or by PCR or RT-PCR (Fig. 5).

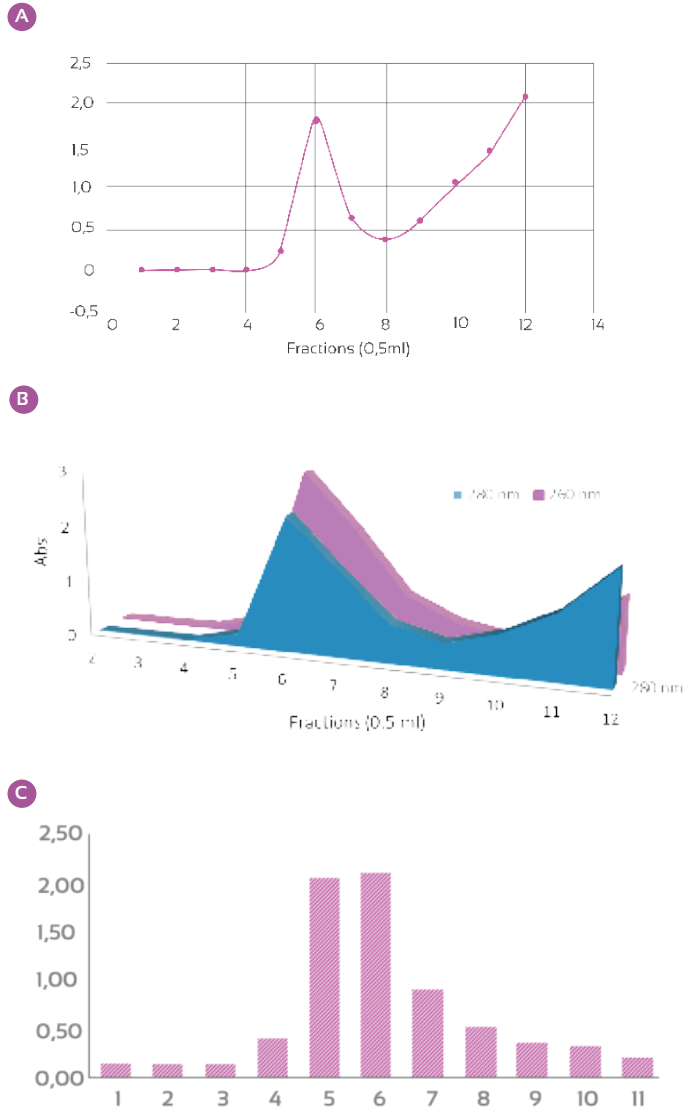

Figure 3. EVs isolation from plasma sample. **A** Elution profile monitored by Abs (280). **B** 260/280 ratio makes it possible to determine more clearly the fractions in which there is a presence of EVs, also identifying in which fractions there is only protein and therefore there are no EVs. **C** Flow cytometric analysis of elution fractions. Stain index: (MFI positive- MFI background)/ 2σ background).

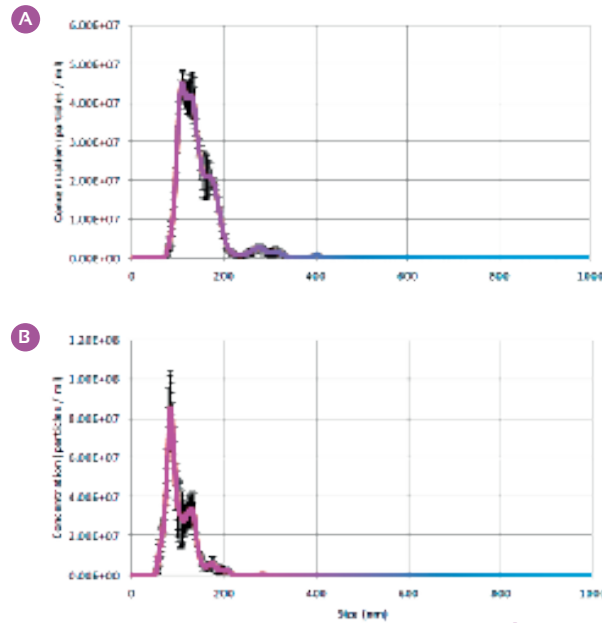
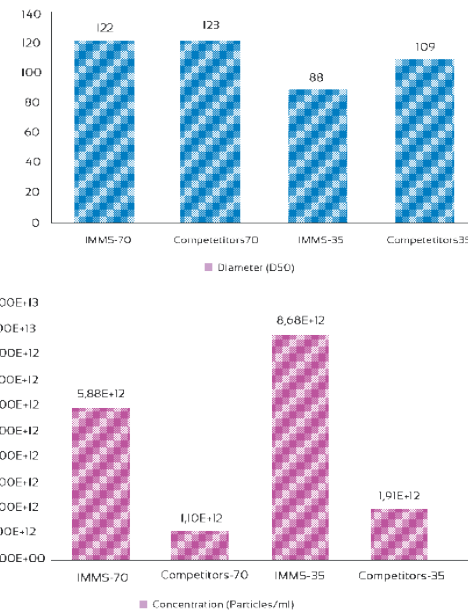

Figure 4. NanoSight analysis of the EVs recovered from Plasma by SEC columns **A** Column reference SEC7012 (70-1000 nm) **B** Column reference SEC3512 (35-350 nm). EVs isolated by SEC resulting in a high level of purity.

A comparison was made using columns competitor, obtaining Immunostep columns a better performance in terms of recovery. A) Comparison of the diameter of the isolated particles by column type. The D50 value means 50% of the particles have that diameter or less. B) Concentration (particles / ml) obtained from purifying plasma (500 μl).



Despite the columns are reusable up to 5 times, a single use is advisable when the downstream analysis is by PCR or RT-PCR.

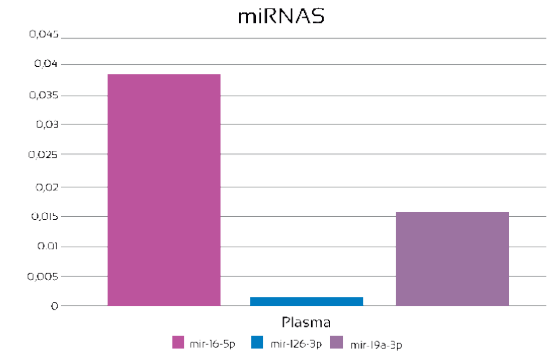

Figure 5. Analysis of the exosomal miRNA levels by quantitative RT-PCR. We followed the instructions in the QIA-GEN Handbook to extract miRNAs, do the RT-PCR to obtain the cDNA and then the qPCR or quantitative PCR. Column protocol does not interfere with the extraction of RNAs, nor with RT-PCR and allows the detection of endogenous miRNAs miR-126-3p, miR-19a-3p and miR16-5p present in the sample.

11. REFERENCES

1. Yáñez-Mó M, Siljander P, Andreu Z, Bedina Zavec A, Borràs F, Buzas E et al. Biological properties of extracellular vesicles and their physiological functions. *Journal of Extracellular Vesicles*. 2015;4(1):27066.
2. Pitt JM, André F, Amigorena S, Soria JC, Eggermont A, Kroemer G, Zitvogel L. Dendritic cell-derived exosomes for cancer therapy. *J Clin Invest*. 2016.
3. Thach M, Théry C. Communication by Extracellular Vesicles: Where We Are and Where We Need to Go. *2016 Cell* 10;164(6):1226-32.
4. Becker A, Thakur BK, Weiss JMI, Kim HS, Peinado H, Lyden D Extracellular Vesicles in Cancer: Cell-to-Cell Mediators of Metastasis. *Cancer Cell* 2016 Dec 12;30(6):836-848.
5. López-Cobo S, Campos-Silva C, Valés-Gómez M. Glycosyl-Phosphatidyl-Inositol (GPI)-Anchors and Metalloproteases: Their Roles in the Regulation of Exosome Composition and NKG2D-Mediated Immune Recognition. *Front Cell Dev Biol*. 2016 Sep 12;4:97.
6. Jonathan M. Pitt, Guido Kroemer, Laurence Zitvogel Extracellular vesicles: masters of intercellular communication and potential clinical interventions. *2016 J Clin Invest*. 2016;126(4):1139-1143
7. Jara-Acevedo R, Campos-Silva C, Valés-Gómez M, Yáñez-Mó M, Suárez H, Fuentes M. Exosome beads array for multiplexed phenotyping in cancer. *J Proteomics*. 2019; Apr 30;198:87-97.
8. Böing, A., van der Pol, E., Grootemaat, A., Coumans, F., Sturk, A. and Nieuwland, R. (2014). Single-step isolation of extracellular vesicles by size-exclusion chromatography. *Journal of Extracellular Vesicles*, 3(1), p.23430.

12. MANUFACTURED BY

IMMUNOSTEP S.L.
Address: Avda. Universidad de Coimbra, s/n
 Cancer Research Center (C.I.C)
 Campus de Unamuno
 37007 Salamanca (Spain)
 (+34) 923 294 827
Tel./fax:
E-mail: info@immunostep.com
www.immunostep.com